

BK 5876PG216

FILED-RECORDED  
RMC / ROD

2007 FEB 26 PM 12:08

MARGARET L. BAILEY  
DORCHESTER COUNTY, SC

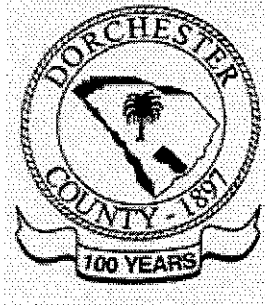

THIS PAGE IS HEREBY ATTACHED AND MADE PART OF  
THE PERMANENT RECORD OF THIS DOCUMENT. IT IS  
NOT TO BE DETACHED OR REMOVED AND MUST BE  
CITED AS THE FIRST PAGE OF THE RECORDED  
DOCUMENT. THE TOP OF THE PAGE IS TO BE USED FOR  
RECORDING PURPOSES AND IS NOT TO BE USED FOR  
ANY OTHER PURPOSE.

REGISTER OF DEEDS  
DORCHESTER COUNTY SOUTH CAROLINA  
MARGARET L. BAILEY, REGISTER  
POST OFFICE BOX 38  
ST. GEORGE, SC 29477  
843-563-0181 or 843-832-0181

13.2

BK 5876PG217

STATE OF SOUTH CAROLINA )  
 )  
COUNTY OF DORCHESTER )

**FENCE GUIDELINES FOR  
REMINISCE**

WHEREAS, a certain corrected Declaration of Covenants and Restrictions for Reminisce was recorded May 8, 2006 in Book 5346 at Page 107 in the RMC Office of Dorchester County (hereinafter "Declaration") because the Declarant desired to provide for the preservation of the values and amenities of the subdivision generally known as Reminisce;

WHEREAS, Article 7 of the Declaration requires the approval of the Architectural Control Committee for Reminisce (hereinafter "ACC") prior to any exterior addition or change including but not limited to fences; and

WHEREAS, the ACC desires to clarify and publish the rules and regulations governing the type of fences are permitted in the subdivision.

NOW THEREFORE, the following shall be the rules governing fences in Reminisce and shall be adhered to by all current and future homeowner when submitting a request for a fence and by the ACC when approving or denying such request.

**DEFINITIONS**

**Change(s)** shall mean any change, alteration, installation, or other similar act that changes the appearance of any Property or the exterior appearance of any structure upon any Lot.

**USE RESTRICTIONS**

**Fences.**

No fence whatsoever shall be erected or allowed to remain in Reminisce except approved fences to be located in rear yards only and set back from Lot lines at such distance as set forth herein. No fences shall be permitted which obstruct the view of any marsh, stream or other body of water when viewed from inside any adjacent Lot.

Said fences and patio fences shall be allowed only after obtaining prior written approval of the Architectural Control Committee (hereinafter "ACC"). If an Owner fails to obtain prior written approval from the ACC for any Changes, a representative of the ACC, its successors and/or assigns, has the right to enter upon any Lot without any prior notice to remove or remedy any unauthorized Changes, i.e. an unapproved fence, at an Owner's expense thirty (30) days following the ACC's written notice to the Owner of the violation and the Owner's failure to cure. If an Owner fails to obtain prior written approval from the ACC and a violation occurs, the Owner shall also be subject to a fine not to exceed Fifty Dollars (\$50.00) per violation per day.

Unless otherwise agreed to in writing by the ACC, fence requests that are not consistent with the following guidelines will not be approved by the ACC.

*J. Stanley Daypool, PA*

1. Location. In addition to the following rules regarding fences, all homeowners shall comply with any Dorchester County ordinance governing the placement and installation of the fences.

a. Fences shall be located in rear of the home. They should begin at the rear corners of the house, extend out towards the side property line, then towards the back property line. (See attached Exhibit A)

b. Rear corner exception – if the rear of the neighboring house is closer to the front of the lot, the fence may begin at the point that is even with the neighbor's rear corner. This will allow for an even fence line between the two homes if both owners install a fence.

c. Corner lots – on the side near the street, the fence shall go directly from the corner of the house toward the rear property line (may not extend out to the side property line).

d. The ACC approves or denies fence requests on the basis of maintaining the overall appearance of the neighborhood. The ACC does not have the authority to give permission to build a fence within an area that is controlled by a 3<sup>rd</sup> party (such as an easement or a right-of-way). The owner shall bear all the risk if a fence is installed in one of these areas.

2. Style (See attached Exhibit B)

a. Privacy fences may be any of these styles: shadow box, scalloped, or Charleston style (trim band at top).

b. Picket fences may be any of these styles: open top, closed top, or scalloped.

c. Wrought iron style – black aluminum that resembles wrought iron is acceptable.

d. Exposed fence posts shall have a decorative cap on top.

3. Size

a. Privacy fences may be built up to 6' in height.

b. Picket fences may be built up to 4' in height.

4. Materials – Fences shall be constructed **only** out of wood. Aluminum fences shall be permitted only if fence style is wrought iron. No other materials including but not limited to vinyl shall be allowed.

5. Colors

a. Wood Fences shall have a natural appearance. Fences may be coated with clear weather sealer. Fences may not be painted white.

b. Aluminum (wrought iron) fences shall be black.

6. Specific restrictions

a. Corner lots and those adjacent to a pond / lake shall be limited to picket or wrought iron style no more than 4' in height. No privacy fences on these lots will be authorized.

b. If a fence is built which "encloses" a garage and the fence (gate) crosses the driveway, the style may only be picket or wrought iron.

[remainder of page intentionally left blank]

IN WITNESS WHEREOF, the Architectural Control Committee of Reminisce Homeowners Association, Inc., sign and set their hand and seal and affixed the seal of the committee this 22 day of FEB, 2007.

[Signature]  
[Signature]

Reminisce Architectural Control Committee

[Signature]

By: [Signature]

By: [Signature]

By: [Signature]

STATE OF SOUTH CAROLINA )  
  )  
COUNTY OF CHARLESTON    )

ACKNOWLEDGMENT

The foregoing instrument was acknowledged before me on this 22 day of February, 2007, by the Architectural Control Committee of Reminisce.

[Signature] (SEAL)  
Notary Public for South Carolina  
My Commission Expires:  
January 24, 2015

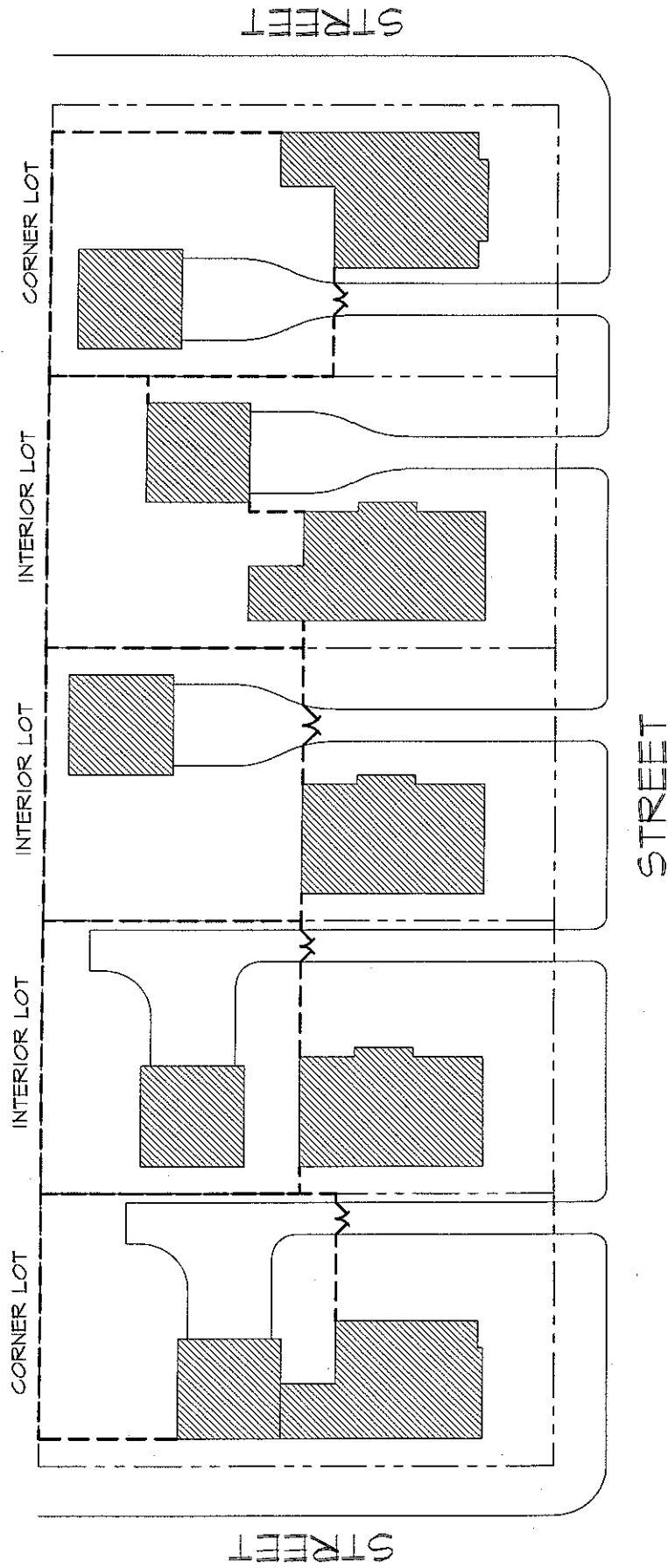

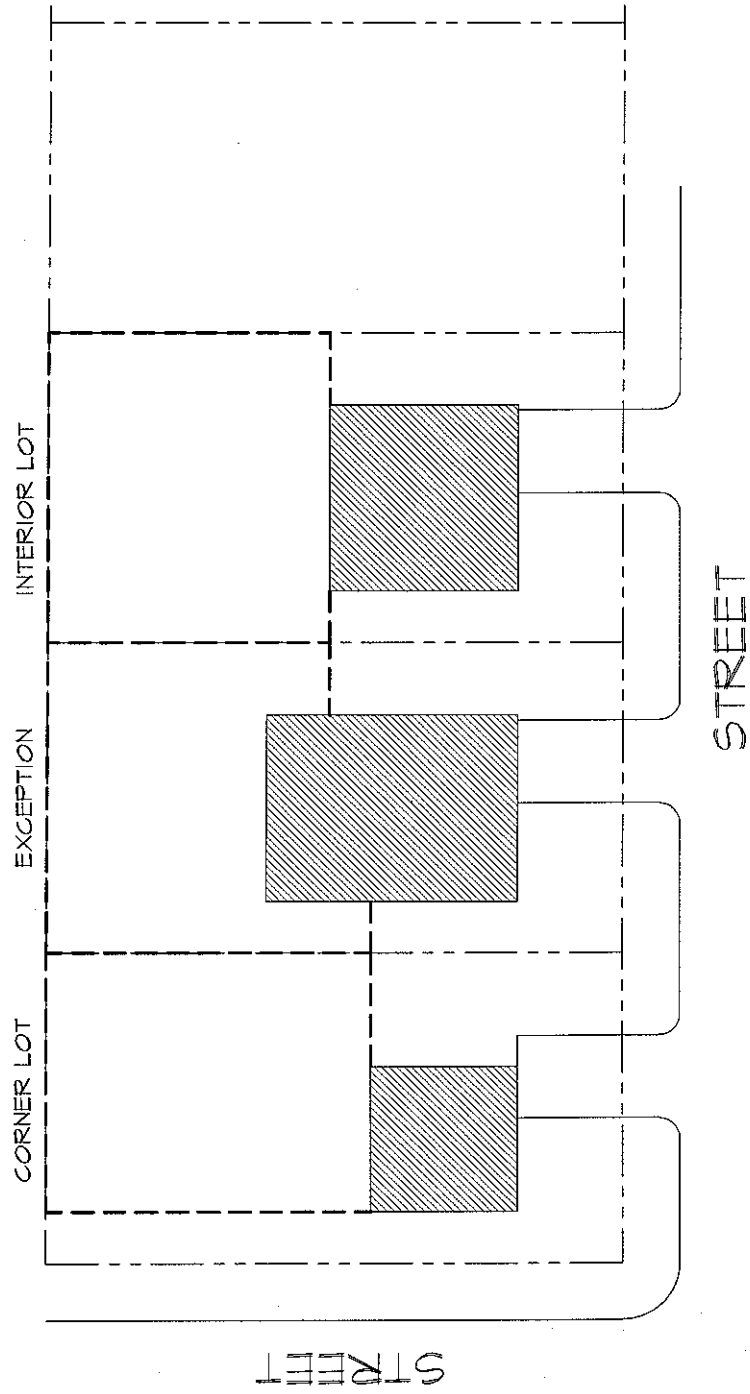

PRIVACY FENCES

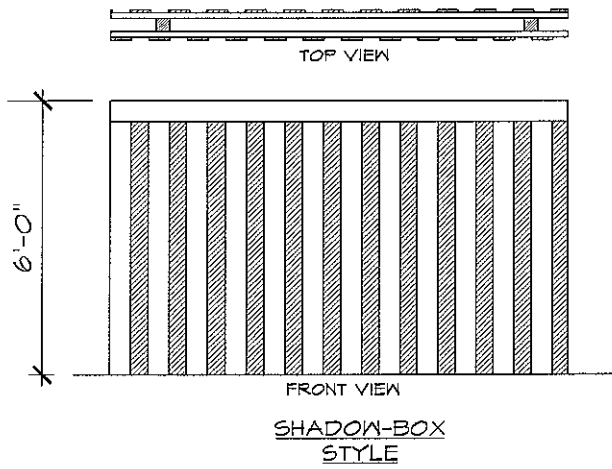
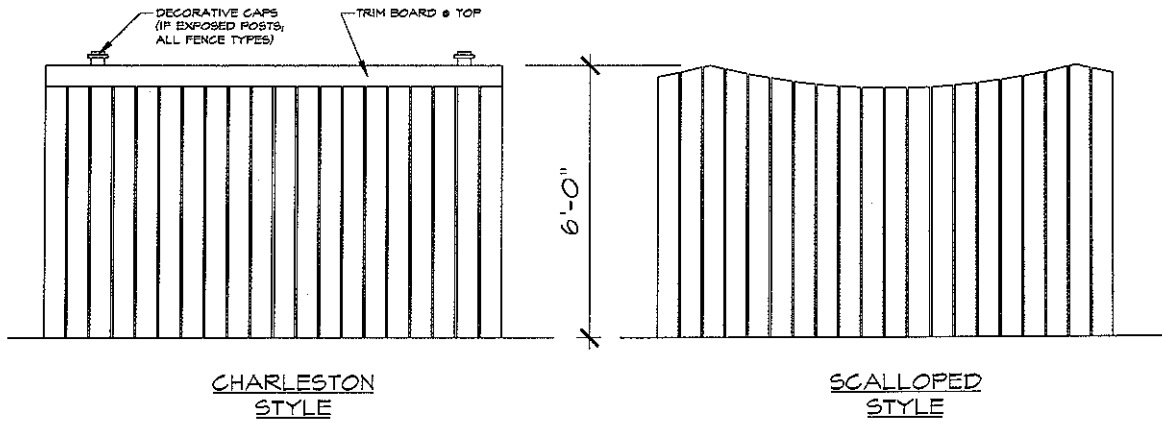

PICKET FENCES

